



# MR315T

IC•Thyristor Controlled  
DC TIG Pulse Welding Machine



**Multi mode for  
high performance**



**MR315T**

**Multi mode for  
High performance**

High Welding quality and high efficiency with DC TIG, Pulsed DC TIG and DC Stick.

**High quality with  
DC TIG welding**

Multi function such as low pulse control (0.5-15Hz), initial current, up slope, down slope and crater fill control.

**High efficiency with  
DC Stick welding**

High efficiency with low spatter is achieved with from 2.6 to 5mm stick electrode.

**Wide application**

Powerful performances for pressure vessel, pipes, plant maintenance, and etc...

## Features

- **High welding quality and high efficiency for mild steel, stainless steel, nickel alloy with DC TIG, Pulsed DC TIG and DC Stick as standard modes.**
- **High performance function for TIG and Pulsed TIG**
- **TIG Pulse function (0.5~15Hz)**  
Ultimate URANAMI (full penetration welding) and bead appearance are achieved with pulsed TIG function. Also, High performance for different material, different thickness and gap.
- **High quality and High efficiency for multi-layer welding**  
First layer with Pulsed TIG for URANAMI. DC TIG for high welding speed from second layer.

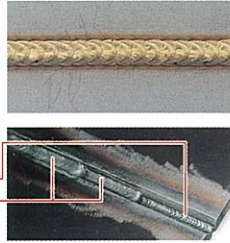

- **Easy-to-see and easy-to-use control panel**

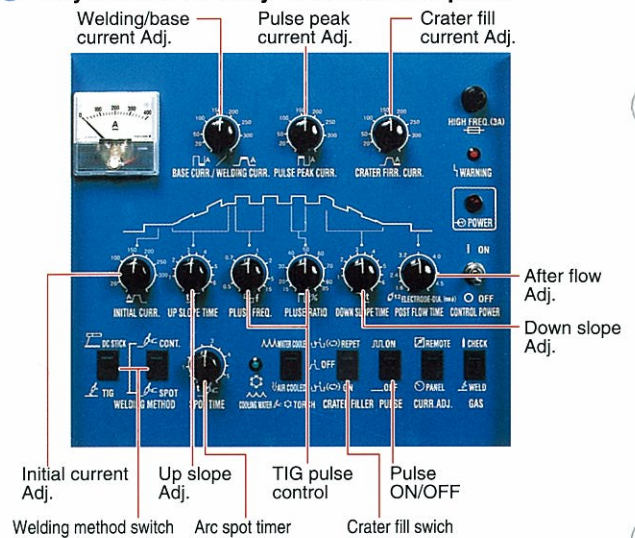

## Information

### Specification

Model Name	MR315T
Model Number	MRHP-315
Rated input voltage	Indicate primary voltage when ordering
Phases	3ph.
Rated frequency	50/60 Hz
Rated input power	16kVA (10kW)
Rated output current	315A
Crater fill/Initial current range	5-315A
Pulse/Base current range	5-315A
Rated out put voltage	22.6V(32.6V at Stick welding)
Max. open circuit voltage	57V
Rated duty cycle	40%
Down-slope time	0.1-5sec
Up-slope time	0.1-5sec
Gas pre-flow time	0.3/0.6sec
Gas after-flow time	3-20sec
Crater fill control	ON/OFF/Repeat
Pulse ratio	15-85%
Pulse frequency	0.5-15Hz
Dimensions (WxDxH)	348mmx592mmx 642mm
Weight	120kg

### Standard Accessories

Description	Specification	Q'ty	Remark
Bolt, Nut, Washer	M5	3 set	on input terminal
Bolt, Nut, Washer	M10	1set	for output terminal
Bolt	M8-20	1	for output terminal

### Connection with power source

Input terminal	M5
Output terminal(⊖)(torch)	φ11 for air-cooled torch 7/8-14UNF for water-cooled torch
Output terminal(⊕)(base metal)	M8
GAS fitting	9/16-18UNF
Water inlet/outlet fitting	5/8-18UNF

### Standard composition (Recommend)

Welding power source	MRHP-315
TIG Torch	AW-18 (4m)
Cable & Hose	BAB-350

## Options

### Remote box (4m)

- Part number : C0031K00
- Optional remote box is available instead of output current adjustment on front panel.



### Remote foot control (8m)

- Part number : 4259-036

### Torch, Cable, Hose

Model Number	AW(F)-17	AW(F)-26	AW-18

### Torch specification

	150A	200A	300A
Rated Current	150A	200A	300A
Cooling Method	Air-cooled	Air-cooled	Water-cooled
Duty cycle	DC 50%, AC 35%	DC 50%, AC 35%	DC 100%, AC 70%
Electrode	0.5-2.4mm	0.5-4.0mm	0.5-4.0mm
Torch length	4m, or 8m	4m or 8m	4m or 8m
Remark	included 4m torch switch(K1108A00) or 8m(K1109A00)		

### Cable & Hose

Part Number	BMRHP-3001	BAB-3501
Remark	3m power cable for base metal & 3m Gas hose	3m power cable for base metal, 3m Gas hose and 2ea, 5m Water hose etc.

### Extension cable for Torch

	BAWH-1504	BAWH-2004	BAWS-3004
+4m	BAWH-1504	BAWH-2004	BAWS-3004
+11m	BAWH-1511	BAWH-2011	BAWS-3011
+16m	BAWH-1516	BAWH-2016	BAWS-3016

## Connection Diagram

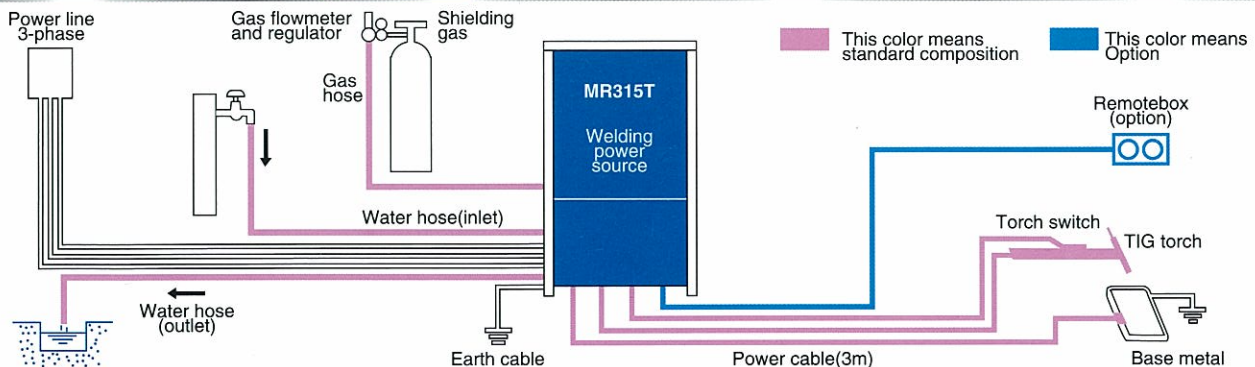

In accordance with DAIHEN's policy to make continuing improvements, design and/or specifications are subject to change without notice and without any obligation on the part of manufacturer.

## DAIHEN Corporation

5-1, Minamisenrioka, Settu, Osaka 566-0021, Japan  
Phone : (Country code 81) 6-6317-2506  
Fax : (Country code 81) 6-6317-2583

Distributed by: